

THE QMS MAGICOLOR 2300 COLOR TONER CARTRIDGE



DOC# 0364

By Mike Josiah and the Technical Staff at Summit Technologies

Remanufacturing the QMS 2300 Color Toner Cartridges



The QMS 2300
Toner Cartridge

First released in September 2002, the QMS Magicolor 2300 series of machines are based on a 16ppm Black 4ppm color print engine. The 2300 series has a base resolution of 600 x 600 Dpi, Enhanced resolution of 2400 x 600Dpi. In January 2003, the 2350 printer was released. While basically the same, it is a slightly better version of the 2300. The 2350 is rated for 18ppm black, 4ppm color, and the enhanced resolution is 9600 x 600 Dpi. A little faster, and better resolution. The 2350 also has printer emulations (PCL6, Postscript) built in where the 2300 is host based. That makes it print faster as well.

One interesting thing with these machines is that there is a humidity/temperature sensor that feeds information to the main PCB. This information is used to help determine what the DC Bias voltages should be for optimum printing.

The machine is reset by setting the gears and track in the "In" position. No chips are used in these cartridges. The reset position will be shown at the end of the article. There is also a piece of mirrored tape on the top left side of the cartridge. This tape is used to detect the presence of the cartridge. If this tape is removed, the printer will not detect the cartridge.

Since these machines were released, QMS was bought out by Minolta. Minolta was then bought out by Konica. The company name at this point in time is Konica Minolta. Most supply catalogs now only list them under

Konica Minolta.

There are High yield cartridges as well as low yield cartridges available. In addition to the toner cartridges, there is also a separate drum unit as well as a waste box. The cartridges used by these machines are as follows:

QMS Magicolor 2300/2350

| | | | |
|-------------|------------|----------------------------------|----------------|
| 1710517-005 | Black HY | 4,500 pages at 5% | \$84.99 List* |
| 1710517-008 | Cyan HY | 4,500 pages at 5% | \$129.99 List* |
| 1710517-007 | Yellow HY | 4,500 pages at 5% | \$129.99 List* |
| 1710517-006 | Magenta HY | 4,500 pages at 5% | \$129.99 List* |
| 1710517-004 | Cyan LY | 1,500 pages at 5% | \$69.99 List* |
| 1710517-003 | Yellow LY | 1,500 pages at 5% | \$69.99 List* |
| 1710517-002 | Magenta LY | 1,500 pages at 5% | \$69.99 List* |
| 1710520-001 | Drum | 45,000 Pages Black, 11,250 Color | \$149.00 List* |
| 1710522-001 | Waste box | 25,000 | \$19.00 List* |

* The pricing on all cartridges is current as of June 2005.

The machines that use these cartridges are as follows:

Magicolor 2300DL
 Magicolor 2300W
 Magicolor 2350EN

They may be listed as QMS, Minolta-QMS, or Konica Minolta it depends on when the list was made. The QMS name has for the most part been let go.

These machines are based on a carousel type color engine. While they are similar to the HP-4500 and 1500, there are differences.

The carousel system is much less expensive to manufacture than the single pass systems (HP-4600). One of the main reasons for this is that the single pass systems have a separate laser-scanner unit and all the associated circuitry for each color cartridge. The carousel system has one for all of them. Because of these differences, we will again go into the printer theory. While this system is not as complicated as a single pass, there is still quite a bit going on that has to happen in a very precise way.

QMS 2300 Color Printing Theory

The QMS 2300 color printing process is best explained as a series of stages. (Figure 1 shows a breakdown of most of the critical printer components as located in the machine.)

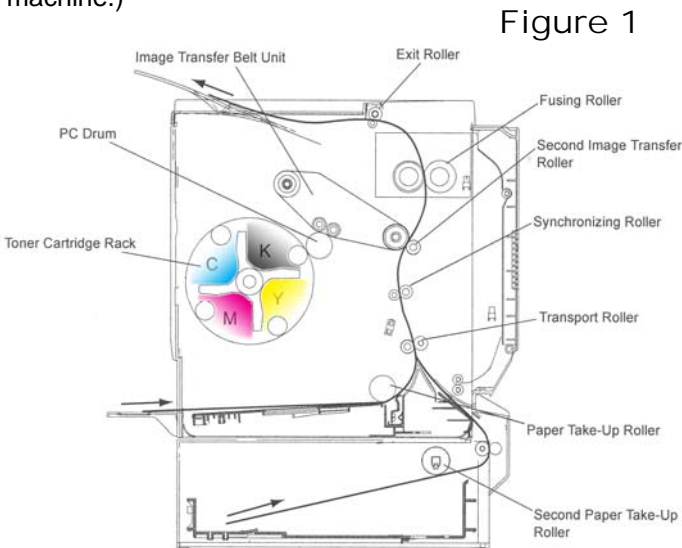

Figure 1

In the first stage, a comb type corona electrode and it's associated grid places a uniform negative DC voltage on the OPC drum surface. The amount of the negative DC voltage placed on the drum is controlled by the printer's intensity setting. This Comb/mesh system reduces the

amount of ozone created; See Figure 2

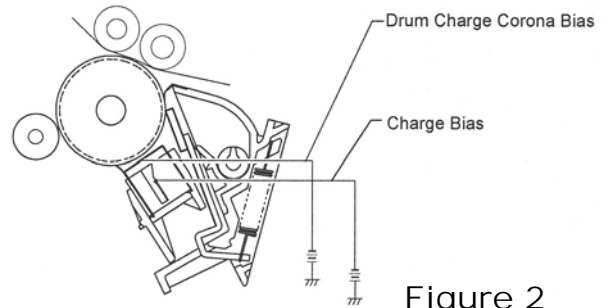

Figure 2

In the second stage, the laser beam is fired onto a rotating mirror (called the scanner). As the mirror rotates, the beam is reflected into a set of focusing lenses. The beam then strikes the drums surface, neutralizing the negative charge and leaving a latent electrostatic image on the drum. The areas where the laser did not strike the drum will retain the negative charge.

Figure 3

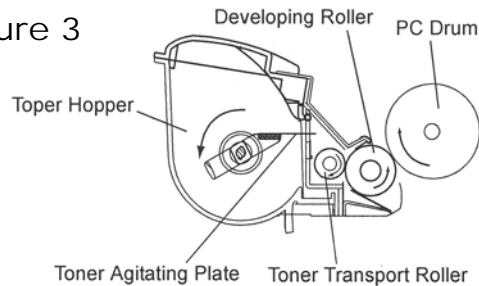
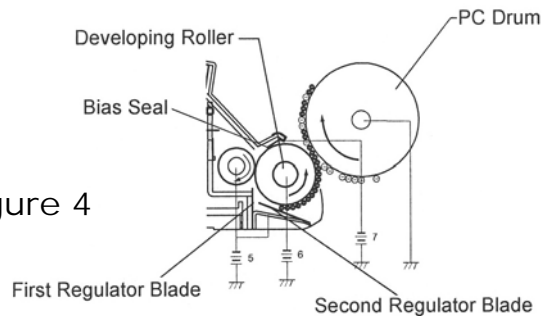

Figure 4



The third or developing stage (See Figures 3 & 4) is where the toner is developed on the drum by the developing section (or supply chamber), which contains the toner particles. As the toner agitating plate turns inside the hopper it pushes the toner towards the toner transport roller. The friction from this process causes a negative potential to develop on the toner. The toner will start to coat the developer roller. At the same time, a negative DC bias voltage is applied to the developer roller. This voltage is controlled by the printer's intensity setting, and causes either more or less toner to be attracted by the developer roller. This in turn will either

increase or decrease the print density. The final amount of toner on the developer roller is controlled by the doctor blade(s) or first and second regulator blades as QMS calls them, which uses pressure and a second DC bias voltage to keep the amount of toner on the roller constant.

As the laser exposed areas of the OPC Drum approach the developer roller, the toner particles are attracted to the drum's surface due to the opposite voltage potentials of the toner, and laser exposed areas of the OPC drum.

The fourth stage is the Primary transfer stage. This is where there are some large differences from monochrome printers and even other color systems, (See **Figure 5**). The first step in the Primary transfer stage is where the first transfer roller places a positive charge on the back side of the transfer belt. The negatively charged toner on the drum is then transferred to the positively charged transfer belt. This process is repeated for each color. The positive DC bias voltage is increased for each successive color to make sure that all the toners stay in place on the belt.

The fifth stage is the secondary transfer stage. As the paper reaches the transfer belt, it also runs by the secondary transfer roller. This roller places a positive charge to the paper which causes the toner to transfer from the belt to the paper. After the transfer process is complete, another DC bias voltage is placed on the Charge neutralizer to remove any residual charges on the paper. After the secondary transfer, the second transfer roller has a DC Bias voltage placed on it to repel any remaining toner on it to the transfer belt. This toner is removed by the cleaning blade. The second transfer roller is then retracted from the transfer belt by a cam mechanism to allow the print cycle to start again. (See **Figure 6**)

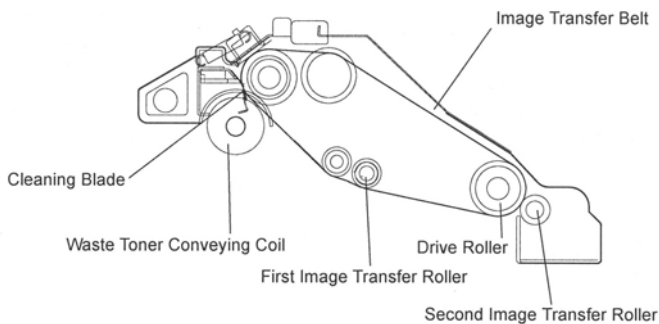

Figure 5

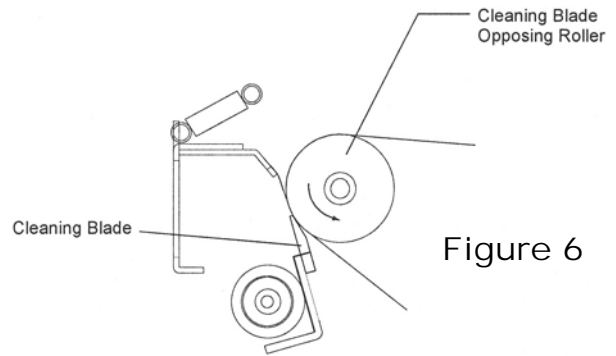

Figure 6

The paper separates from the transfer belt with the help of the static charge eliminator and the stiffness of the paper.

In the sixth stage, the image is then fused onto the paper by the fuser assembly. The fuser Assembly is comprised of the upper fuser roller and lower pressure roller. The lower pressure roller presses the page up into the upper fuser roller which then melts the toner into the paper. The upper heating assembly consists of a hard Teflon coated upper roller and a halogen bulb inside. This is basically the old style of fuser that has been used for years.

The seventh stage is where the transfer belt is cleaned. The cleaning blade is also cam activated, and moves in for the cleaning cycle. The waste toner is moved into the waste bottle by a coil that moves the toner into the waste bottle. After the cleaning cycle, the cleaning blade moves away from the transfer belt to help prevent excess wear to the transfer belt.

Printer Calibration:

At the start of all this is the calibration cycle. The printer will calibrate itself whenever the printer is turned on, when a new toner or drum cartridge is installed, and at specific page intervals determined by the total number of pages printed. Calibration consists of a solid block and halftone of each color being printed to the transfer belt. As the printed areas get to the top of the belt, a sensor will detect them, measure the density, and adjust the printer accordingly.

Taking test prints, cartridge troubleshooting as well as minor printer troubleshooting will be covered at the end of this article.

Required Tools

Toner approved vacuum or toner approved dust collector system
A small screw driver (Common Style)
A Phillips head screwdrivers
Needle Nose Pliers
Jewelers screwdriver set

Supplies Required

2300 Dedicated Color Toner
Shipping cover
Lint free Cloths
Conductive grease

1) On the gear side of the cartridge, remove the three silver screws from the end cap. See **Figure 7**

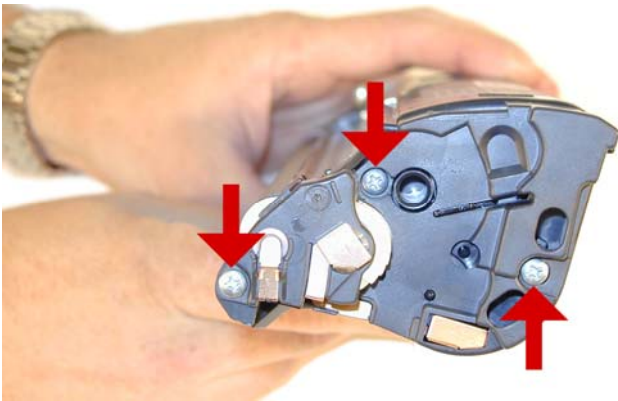

Figure 7

2) Remove the small black screw from the underside contact. See **Figure 8**

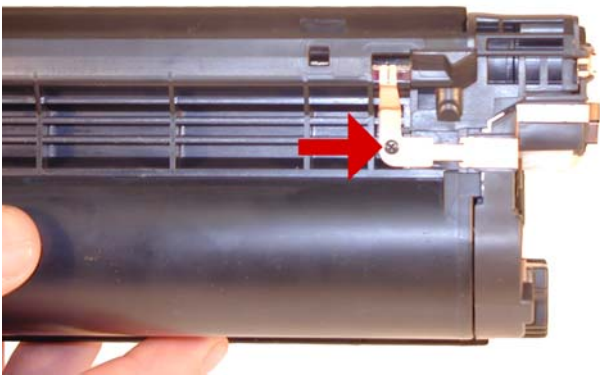

Figure 8

3) Gently pry up the contact. Remove the end cap. See **Figure 9**



Figure 9

4) Remove the black reset gear train. See **Figure 10**

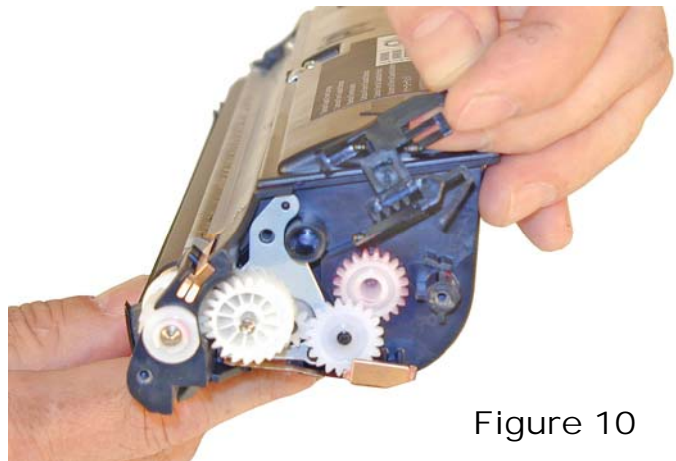

Figure 10

5) Remove the larger drive gear and the two smaller gears next to it. Leave the mixing blade gear in place. See **Figure 11**



Figure 11

6) Remove the color cover screw and end cap. See **Figure 12**



Figure 12

7) Remove the fill plug, and dump out any remaining toner. See **Figure 13**



Figure 13

8) Remove the small white bushing from the gear side. See **Figure 14**

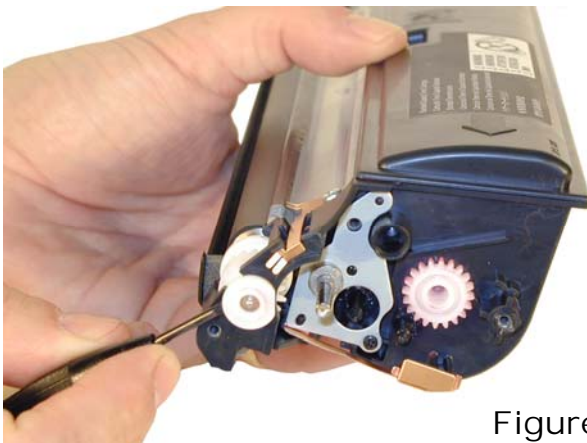

Figure 14

9) Remove the white bushing from the non-gear side by prying up the center tab and rotating the bushing clockwise until it stops. Pry the bushing off the developer roller shaft. See **Figure 15**



Figure 15

10) Remove the doctor blade cover by prying up the three tabs as indicated. Remove the cover. See **Fig. 16**



Figure 16

11) Remove the developer roller. See **Figure 17**



Figure 17

12) Remove the two screws from the "first" doctor blade. (The second doctor blade is located under the feed roller). Remove the doctor blade. See **Figure 18**

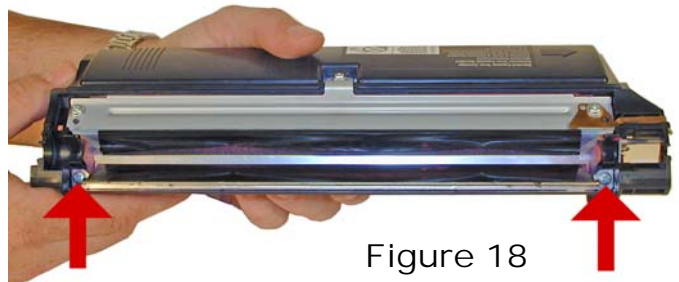

Figure 18

13) Remove the three screws on the sealing blade assembly. See **Figure 19**

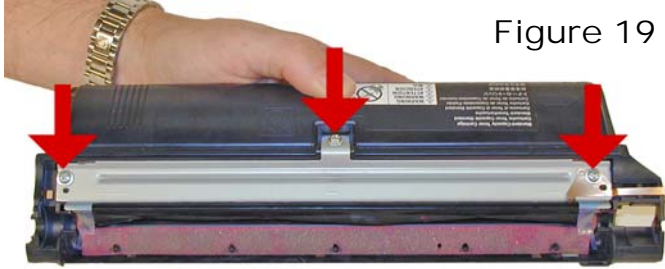

Figure 19



Figure 22

14) Remove the copper contact. See **Figure 20**

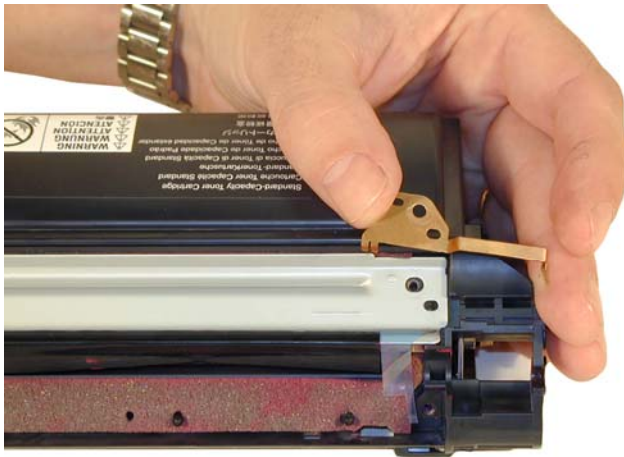

Figure 20

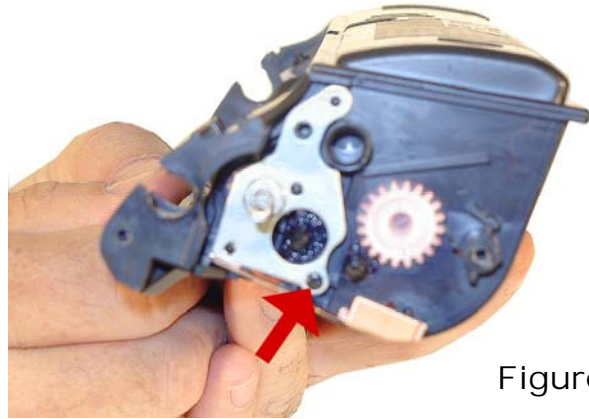

Figure 23

18) Check to ensure that the contact to the feed roller is clean, and that the two gears are clean and greased. If not clean them and re-grease the gears with white lithium grease. See **Figure 24**

15) Pry up the sealing blade assembly and lift off. The entire foam seal assembly will come off with it. Be careful not to tear the seals. See **Figure 21**

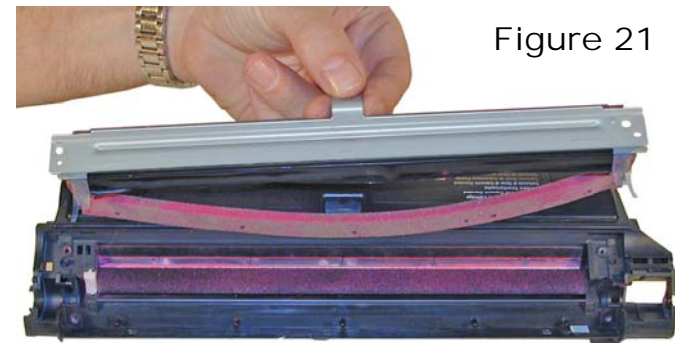

Figure 21

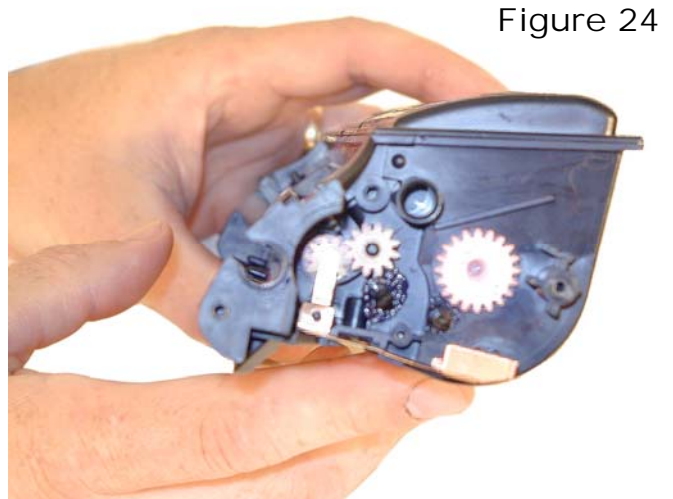

Figure 24

16) Clean out any remaining toner from the hopper and the feed roller. See **Figures 22**

17) Remove the small screw from the feed roller contact plate, remove the plate. See **Figure 23**

19) Re-install the feed roller contact plate and screw. See **Figure 25**

20) Install the cleaned sealing blade assembly, seals, contact, and three screws. Make sure the foam aligns with the plastic pins. See **Figure 26**

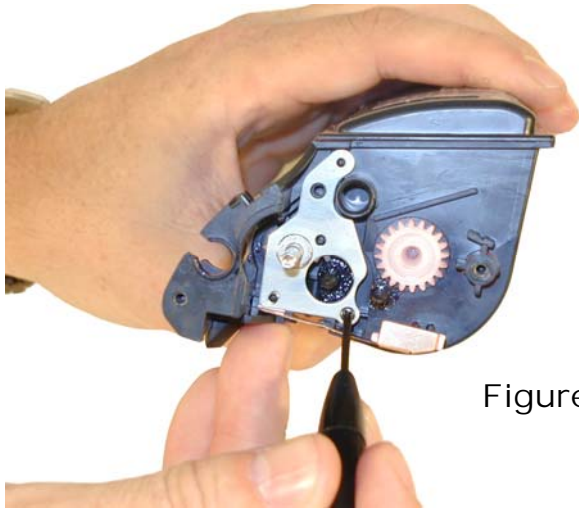

Figure 25



Figure 26

21) Install the first doctor blade and two screws. See **Figure 27**



Figure 27

22) Install the developer roller assembly. See **Figure 28**



Figure 28

23) Install the small bushing on the developer roller shaft. Note the two small alignment tabs on the bushing. See **Figures 29**



Figure 29

24) Install the large white bushing tab up, and rotate counter-clockwise to lock in place. See **Figures 30 & 31**



Figure 30



Figure 31

25) Install the three gears smallest to largest in that order. See **Figure 32**

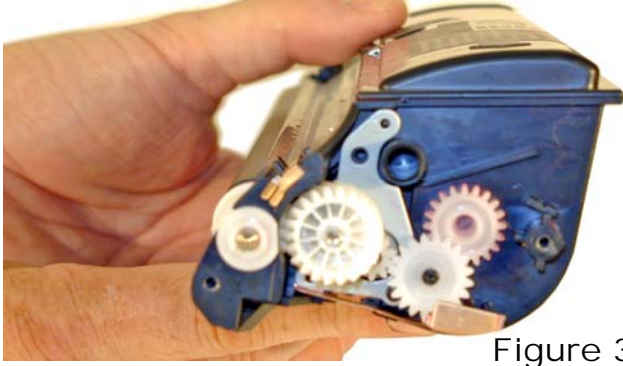

Figure 32

26) Install the black reset assembly so that the gears mesh, and the u-shaped section of the assembly is against the round post. If the assembly is set further out, the printer will not be reset. See **Fig. 33**

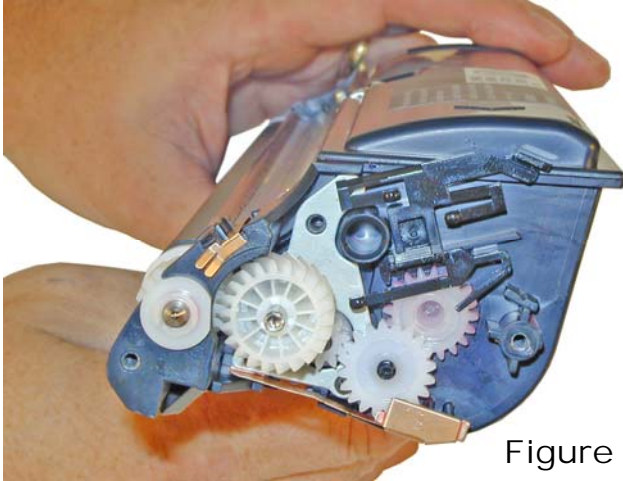

Figure 33

27) Install the black end cap on the gear side. Press the contact in place, and install the small black screw. Install the three silver screws. See **Figure 34**

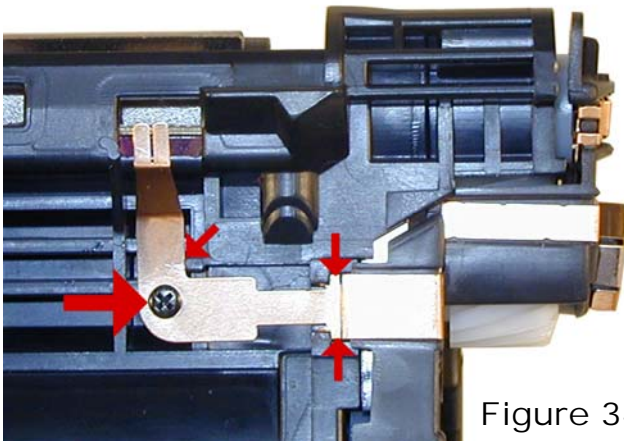

Figure 34

28) Install the DB cover. Rotate so that the tabs are aligned and snap in place. This will take a bit of force to fit properly. See **Figure 35**



Figure 35

29) Fill with the appropriate QMS 2300 color toner, replace the fill plug. See **Figure 36**

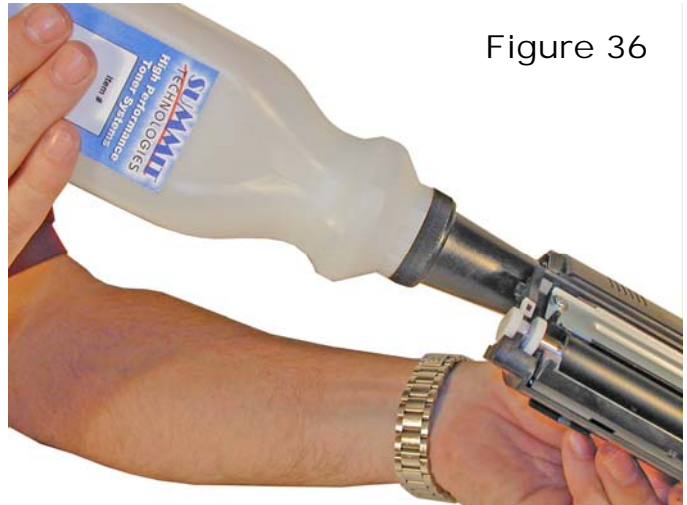

Figure 36

30) Install the color cover and screw. This cover should be able to move. The screw does not lock it down tight. See **Figure 37**



Figure 37

31) Install the developer roller cover. See **Figure 38**



Figure 38

Taking Test Prints

With the printer ready, press the "MENU SELECT" button once.

Press the left or right arrows until "QUALITY MENU" appears on the display.

Press the "MENU SELECT" button.

Press the left or right arrows until "TEST PAGE 1 or TEST PAGE 2" appears on the display.

Test page 1 prints out 5 pages one of each color. Test page 2 is a black/gray scale page.

Press the "MENU SELECT" button.

Cartridge Troubleshooting:

A dirty Corona wire (electrode) and or grid will cause random streaks of toner vertically down the page.

A Scratched Drum will show up as a very thin, perfectly straight line that runs from the top to the bottom of the test page.

A Chipped Drum will result in a dot or series of dots that repeat 3x/page

A Damaged Developer Roller will either leave a mark or a blank spot (depending on the type of damage.)

A Light Damaged Drum will show up as a shaded area on the test print that should be white. Again this will repeat 3x/page.

A Bad Wiper Blade will result in vertical shaded lines down the page, or as shading across the entire page. In either case there will be a film of toner on the drum surface.

Some of the more common Printer Error Messages:

Most error codes are self explanatory, but a few are numeric. We have included some of the more common ones here.

| | |
|------------------------|-----------------------------------|
| Fatal Error 08H | Main motor not rotating |
| Fatal Error 0BH | fan motor not rotating |
| Fatal Error 0EH | Fuser fan not rotating |
| Fatal Error 10H | Scanner motor error |
| Fatal Error 16H | Transfer belt not rotating |
| Fatal Error 17H | Toner cartridge rack not rotating |
| Fatal Error 18H | Fuser Assembly heat error |
| Fatal Error 19H | Fuser Assembly heat error |
| Fatal Error 1AH | Fuser Assembly heat error |
| Fatal Error 1BH | Fuser Assembly heat error |